

Before you begin to assemble your new piece of furniture please check to ensure all parts and fittings have been supplied. Follow all instructions closely as deviation from them may void warranty and present possible safety risk. It is recommended that assembly is done on a soft surface, like carpet, to avoid damage. CARE INSTRUCTIONS: Periodically re-tighten all fasteners. TOOLS REQUIRED: Allen key (provided), Some packs may come with timber of a different colour to the model purchased. These pieces are for packing purposes only.

If you experience any problems with your new purchase please phone our Customer Service staff on (FREE CALL PHONE / FAX) 1800 029 715

Please keep last page of the instruction for warranty information.





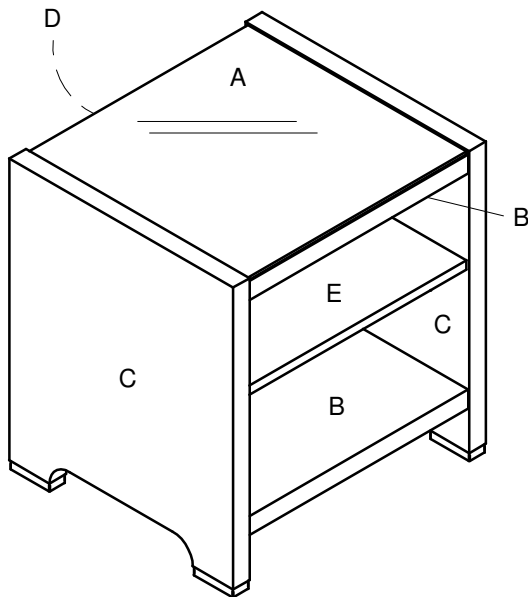



CLEANING AND MAINTENANCE: Do not use solvent or alcohol based cleaners on this unit. To clean unit, we recommend using a warm damp cloth to wipe over surfaces.

PARTS CHECKLIST

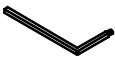

CODE	PART	SIZE	QTY
A	GLASS TOP	435 x 435	1
B	TOP / SHELF	437 x 440	2
C	SIDE	520 x 445	2
D	RAIL	437 x 64	1
E	ADJUSTABLE SHELF	435 x 435	1

FITTINGS CHECKLIST

CODE	FITTING	DESCRIPTION	QTY	CODE	FITTING	DESCRIPTION	QTY
50-001		32mm WOODEN DOWEL	12	50-043		HI LO SCREW	8
50-007		SHELF SUPPORT	4	50-425		BUMP STOP	4
50-009		4mm ALLEN KEY	1	51-511		FOOT	4
50-015		METAL CAM	4	80-001		GLUE	1
50-016		METAL DOWEL	4				

STEP 1: PREPARE SIDES

50-016
x 4



50-043
x 8



51-511
x 4

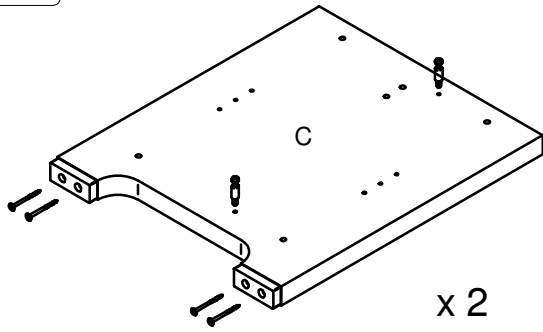

STEP 2: PREPARE TOP / SHELF

50-001
x 8



50-015
x 4

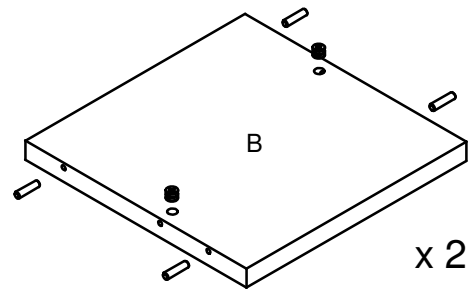

STEP 3: PREPARE RAIL

50-001
x 4

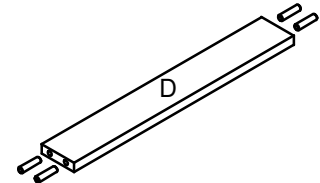

STEP 4: ATTACH TOP / BASE / RAIL TO SIDE



TURN CAM (50-015)
CLOCKWISE TO LOCK

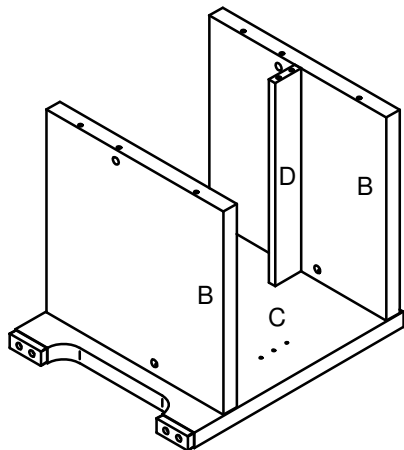

STEP 5: ATTACH OTHER SIDE



TURN CAM (50-015)
CLOCKWISE TO LOCK

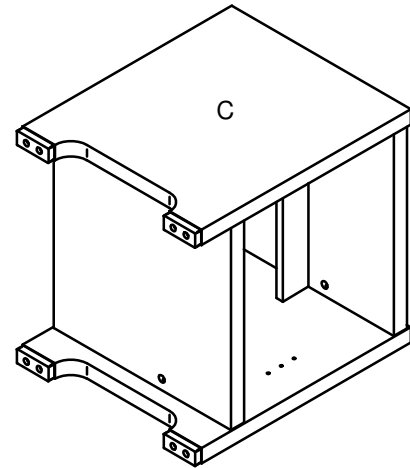

STEP 6: INSERT SHELF SUPPORTS AND BUMP STOPS

50-425
x 4



50-007
x 4

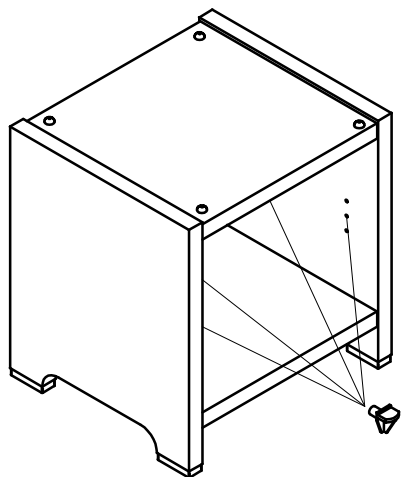

STEP 7: INSERT SHELF AND GLASS TOP

